

## Belt grinding unit

# UBC 9-R

### Applications

Powerful, lightweight belt grinder. For clean-ing and removing burrs, defining a radius, blending surface finishes, fillet weld grinding and finishing, tight access applications and generating decorative satin finishes on metal.

- Heavy duty electric belt grinder
- Tacho variable speed selector – 3 000 to 8 200 min<sup>-1</sup>, variable from 945 to 2 598 SFPM
- A selection of 6 steel contact arms
- Complete selection of belts 20 1/2" (520mm) long, from 1/8" (3mm) to 3/4" (19mm) wide
- Warning light when carbon brushes need changing. LED (at the back of the black case)

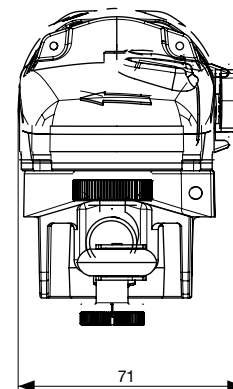

Technical data				
Type	Order No.	Speed min <sup>-1</sup>	Belt speed m/s	Weight kg
UBC 9-R	111 297	3 000 – 8 200	4,8 – 13,2	1,950
Fully insulated single phase motor		Power input	Belt dimensions	
230V 50Hz		600 W	6 × 520 mm, 12 × 520 mm	

## Tube polisher

# UTC 9-R

- Up to 180° contact on tubes
- Grinding of tubes with a ø of up to 45mm
- Integrated overload cut-out
- Tacho variable speed selector for constant speed
- Soft-start for jolt free work
- Warning light when carbon brushes are worn: LED (at the back of the black case) lights up as soon as the carbon brushes need changing.

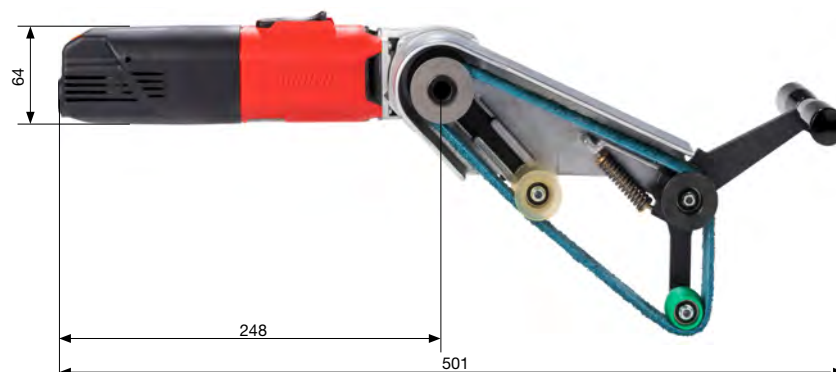
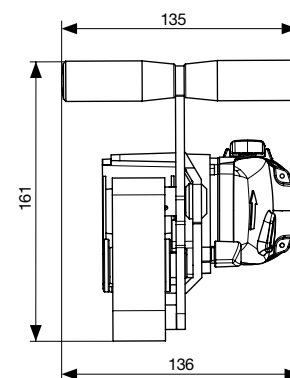

Technical data						
Type	Order No.	Power input	Belt dimensions	Speed min <sup>-1</sup>	Belt speed m/s	Weight kg
UTC 9-R	111 299	600 W	30 × 533 mm	3 000 – 8 200	4,6 – 12,5	2,550

## Tube polisher

# UTG 8-R

- Up to 180° contact on tubes
- Grinding of tubes with a  $\varnothing$  of up to 45 mm
- Integrated overload cut-out
- Tacho variable speed selector for constant speed
- Soft-start for jolt free work
- Warning light when carbon brushes are worn: LED (at the back of the black case) lights up as soon as the carbon brushes need changing.

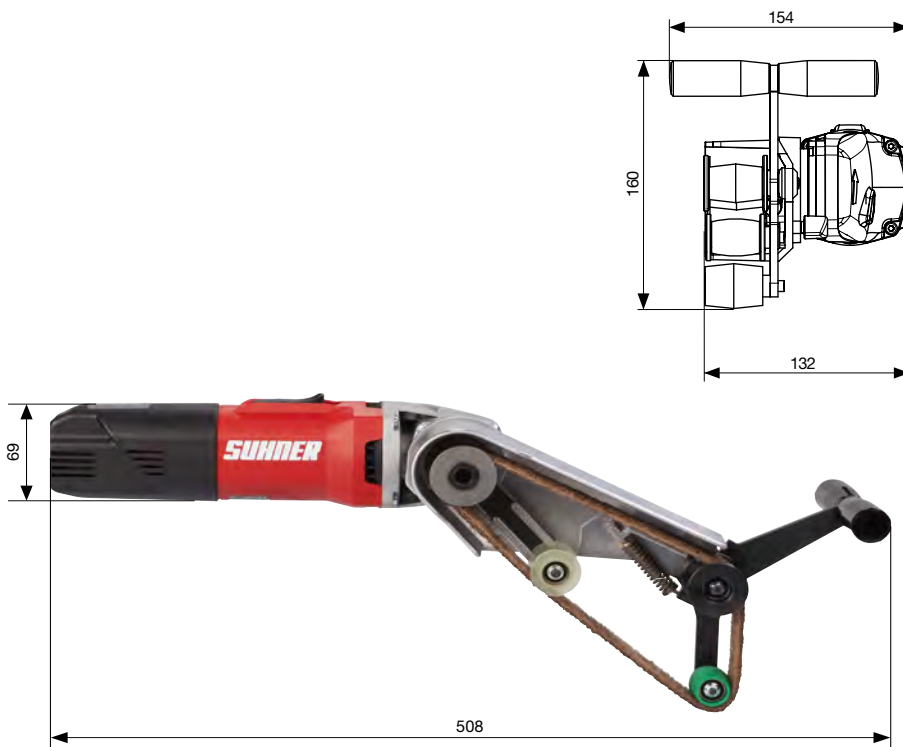

### Technical data

Type	Order No.	Power input	Belt dimensions	Speed min <sup>-1</sup>	Belt speed m/s	Weight kg
UTG 8-R	111 269	1050 W	30 × 533 mm	4 000 – 9 000	6,15 – 13,6	2,900

# UTG 9-R

- Up to 220° contact on tubes
- Grinding of tubes with a  $\varnothing$  of up to 70 mm
- Larger Diameter with Less contact wrap
- Overload cut-out integrated
- Soft-start for jolt free work
- Digital electronics ensures constant working speed
- Undervoltage protection. Unintentional activation following a voltage interruption, even with the machine on, is impossible

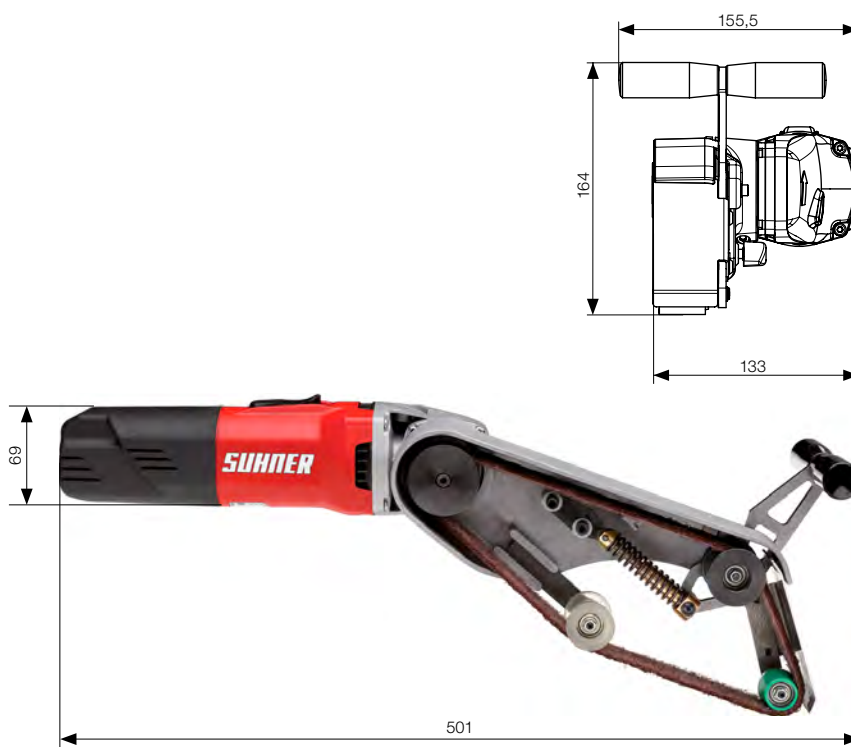

### Technical data

Type	Order No.	Power input	Belt dimensions	Speed min <sup>-1</sup>	Belt speed m/s	Weight kg
UTG 9R	111212	1050 W	30 × 610mm	4 000 – 9 000	7 – 15,5	2,550